

H 3-3

4.5-ZIMMER- MAISONETTE- GARTEN-WOHNUNG

Geschoss: EG/1. OG
Nettowohnfläche: ca. 121 m²
Aussenfläche: ca. 25 m²
Keller: ca. 7 m²

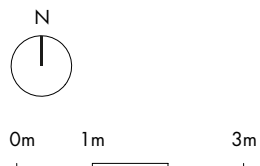
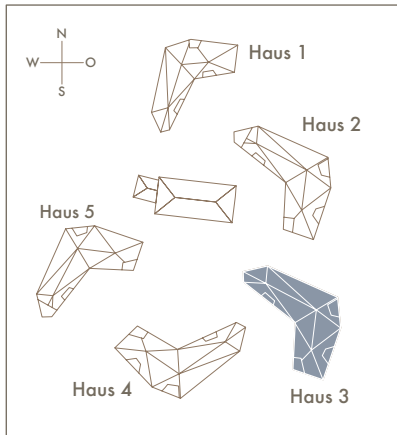
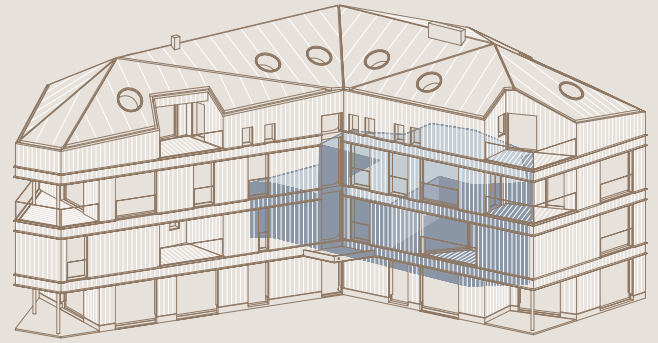

Exklusiv Möblierung | Änderungen vorbehalten

LIEBWyLEN