

H 1-6

3.5-ZIMMER- MAISONNETTE- WOHNUNG

Geschoss: 1./2. OG
 Nettowohnfläche: ca. 111 m²
 Aussenfläche: ca. 8 m²
 Keller: ca. 6 m²

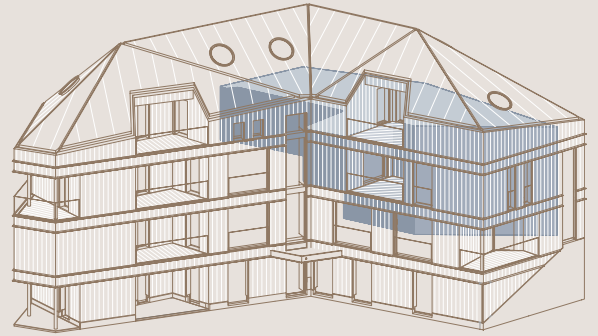

2. OG

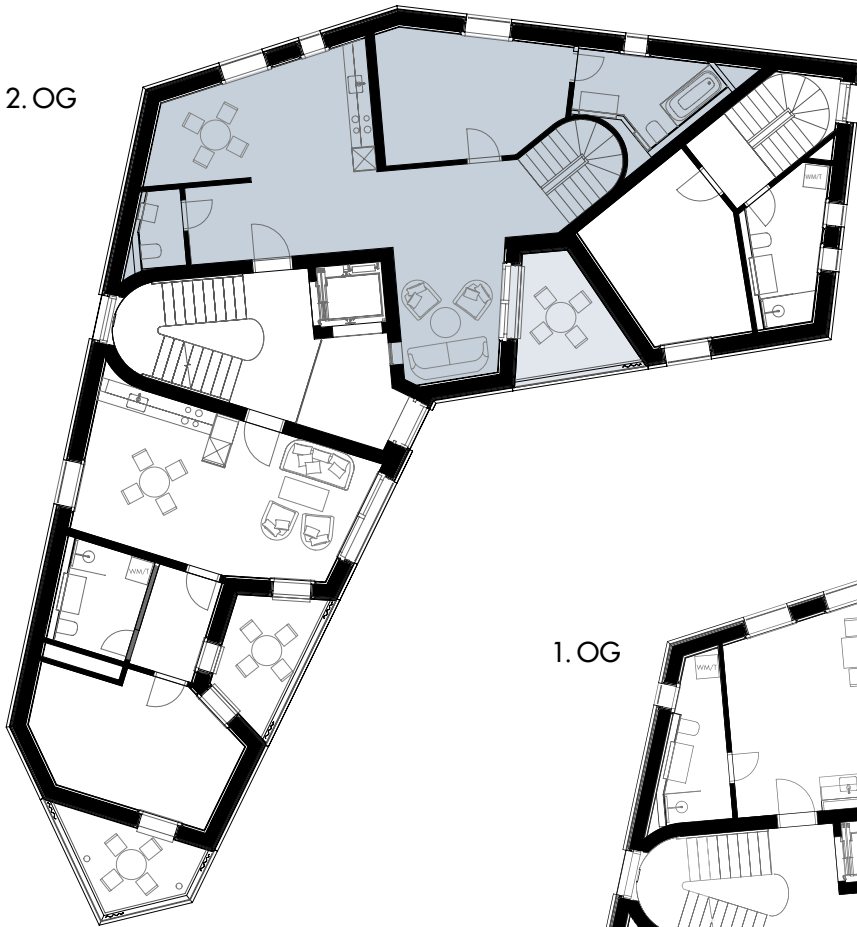

1. OG

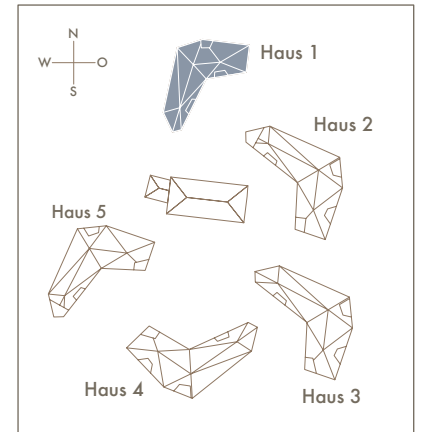

0m 1m 3m

Exklusiv Möblierung | Änderungen vorbehalten

LIEBWyLEN

Vermietung

Liebwylen Immobilien AG c/o Mattig Suter und Partner, Bahnhofstrasse 28, 6431 Schwyz, www.liebwylen.ch