

H 1-5

2.5-ZIMMER- WOHNUNG

Geschoss: 2. OG
Nettowoohnfläche: ca. 57 m²
Aussenfläche: ca. 15 m²
Keller: ca. 6 m²

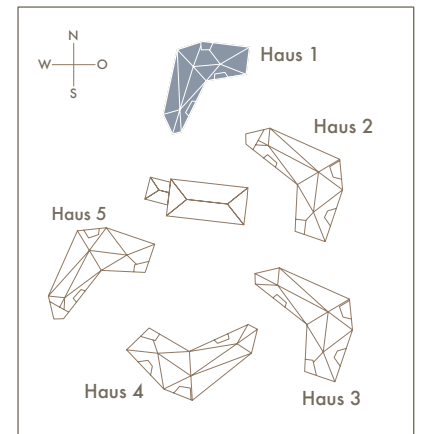
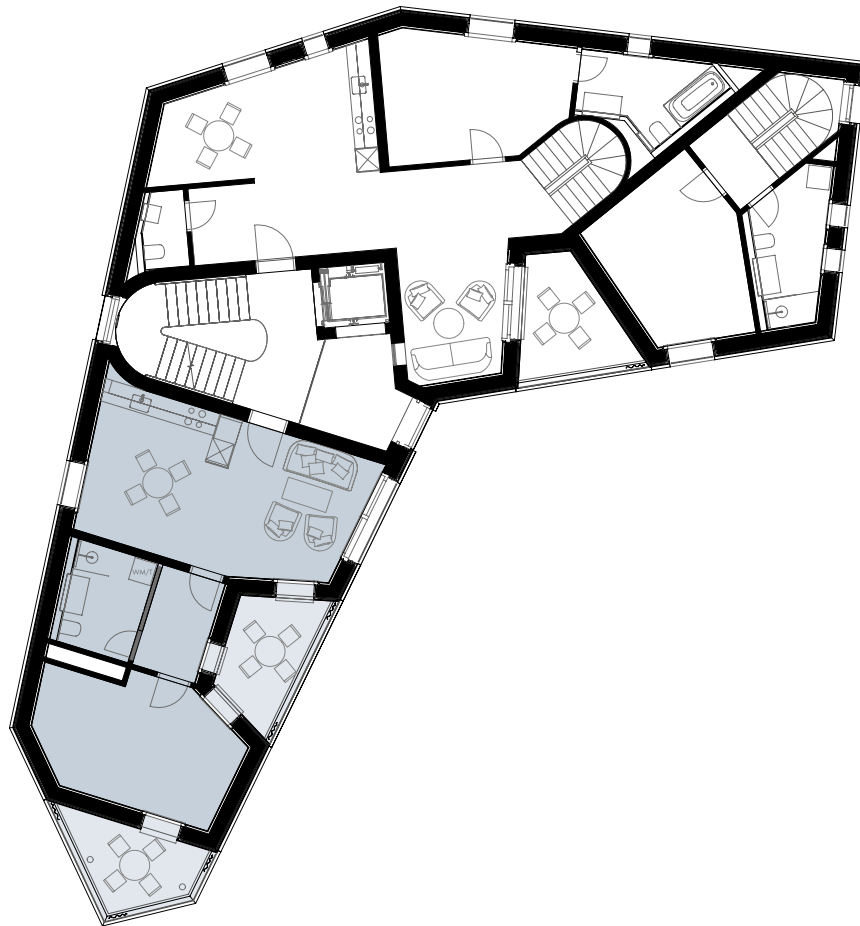
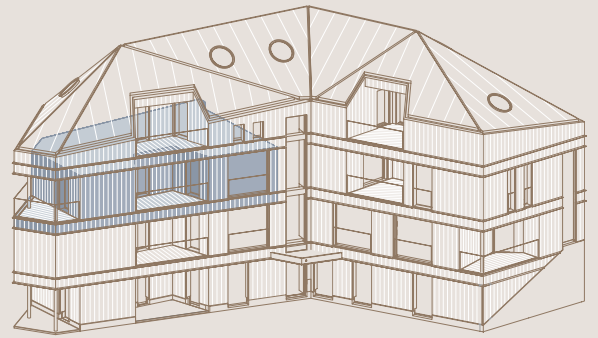

0m 1m 3m

Exklusiv Möblierung | Änderungen vorbehalten

LIEBWYLEN